

750ml Bottle Specification Details

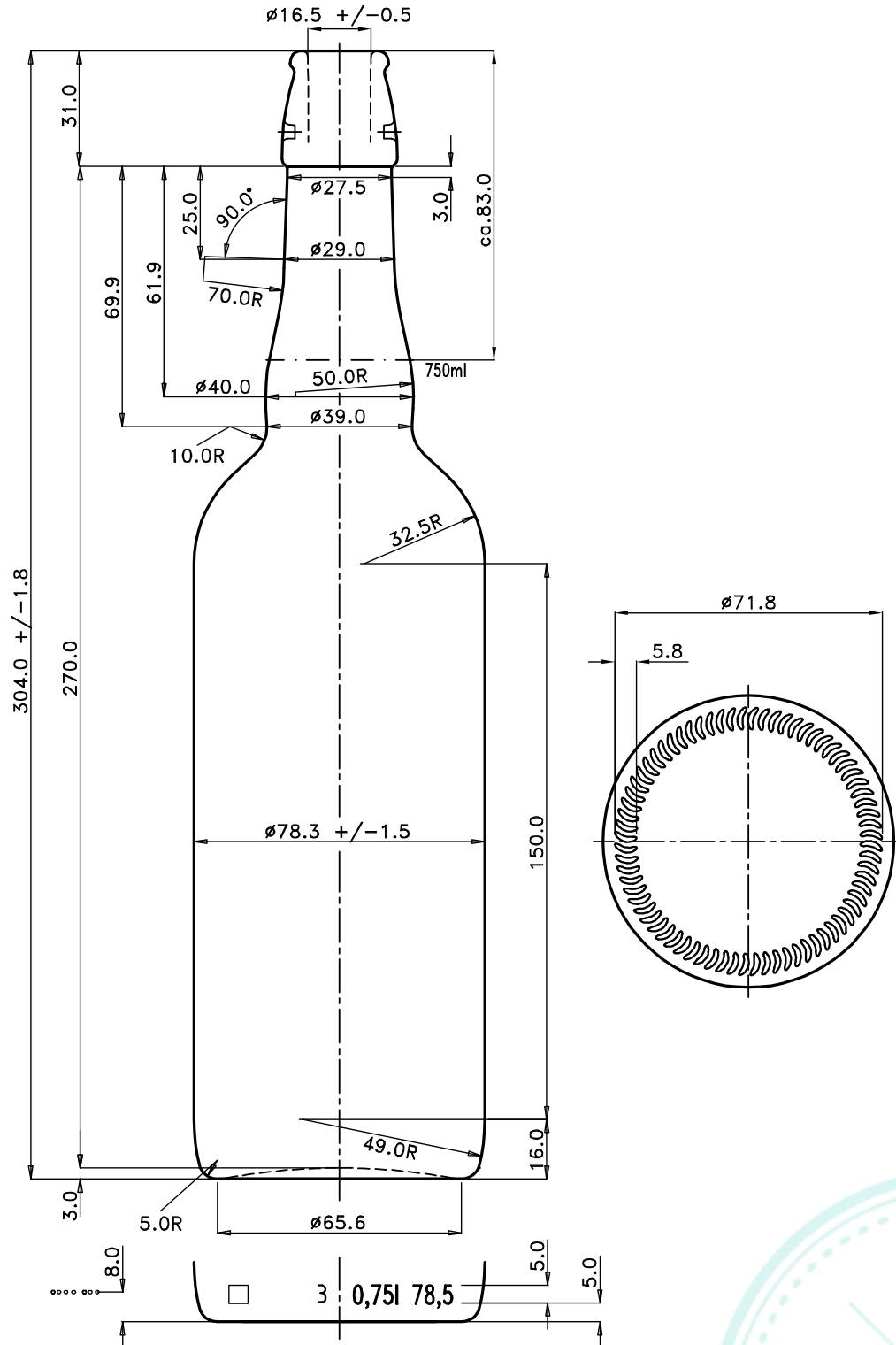

DRAWING SUBJECT TO TRIAL & APPROVAL

DESCRIPTION:	750ml Belgian Combi Finish		ITEM CODE:	CRWI3750-9E	
COLOUR:	Amber		WEIGHT:	530g	
NOMINAL CAPACITY:	750ml	BRIMFUL CAPACITY:	785 \pm 10ml	CLOSURE:	Combi Finish
PASTEURISATION:		TYPE:		THERMAL SHOCK:	
HEIGHT:	304 \pm 1.8mm	DIAMETER:	78.3 \pm 1.5mm	FILL HEIGHT:	83mm
LABEL PANEL:	150mm	CARBONATION:	16 Bar	VACUITY:	35ml
PALLET HEIGHT:	2.00m	PALLET WEIGHT:	760kg	UNITS PER PALLET:	1,421
DRAWING CHECKED:	TIM	DATE CHECKED:	30-JAN-2017	DRAWING REF:	10-082

All measurements are approximate unless tolerances stated, then are in accordance with ISO9058:2008, E&OE Excepted. Clients should run trials and check physical samples prior to any full scale production.

QF015 Iss 005 01/07/2016