

EUROPE

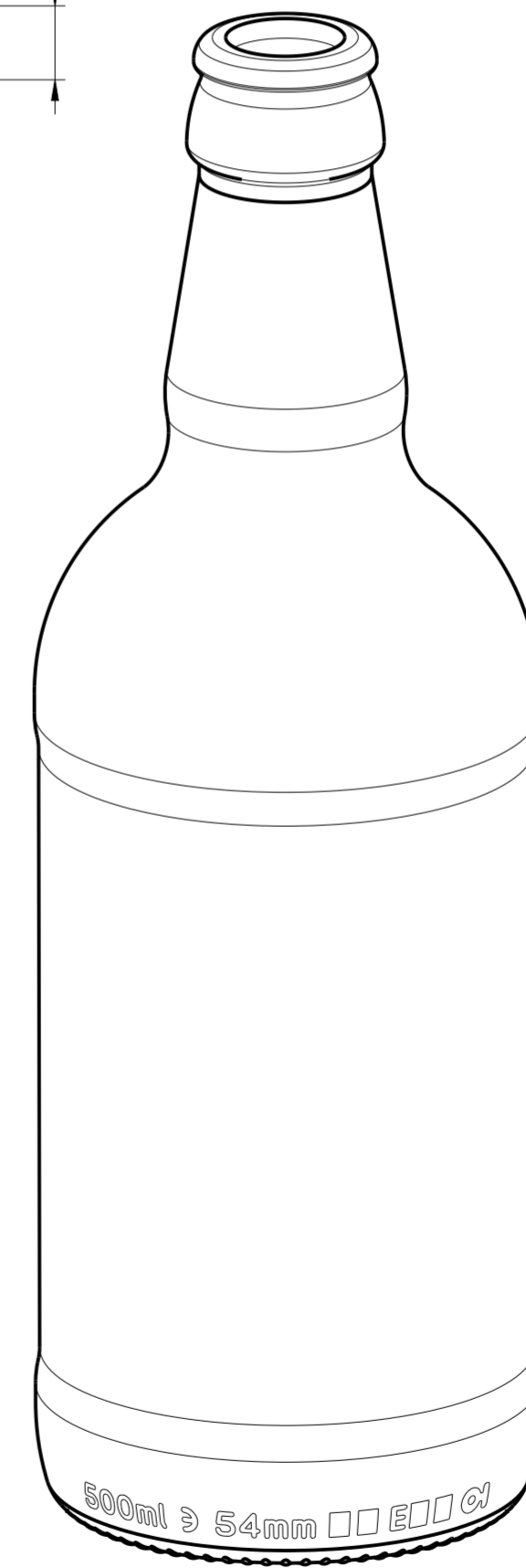
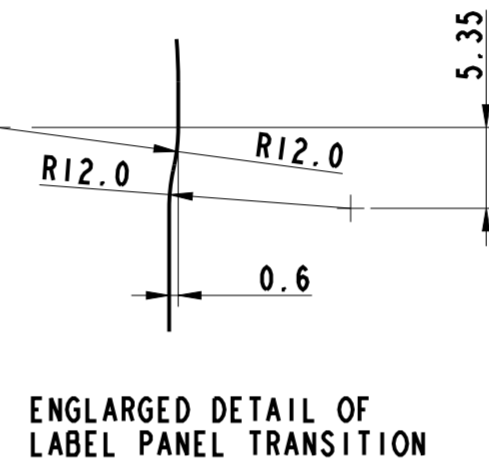
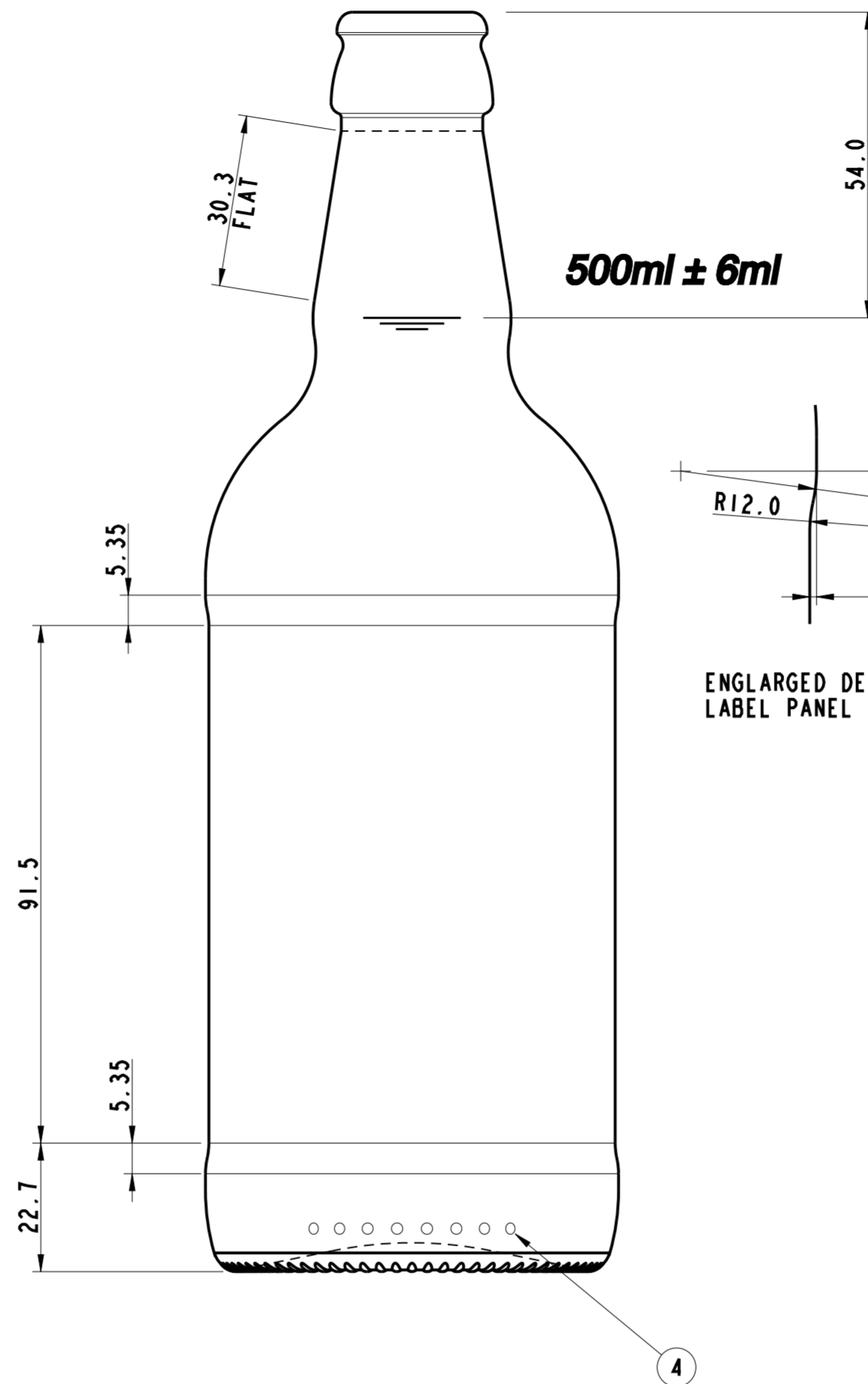
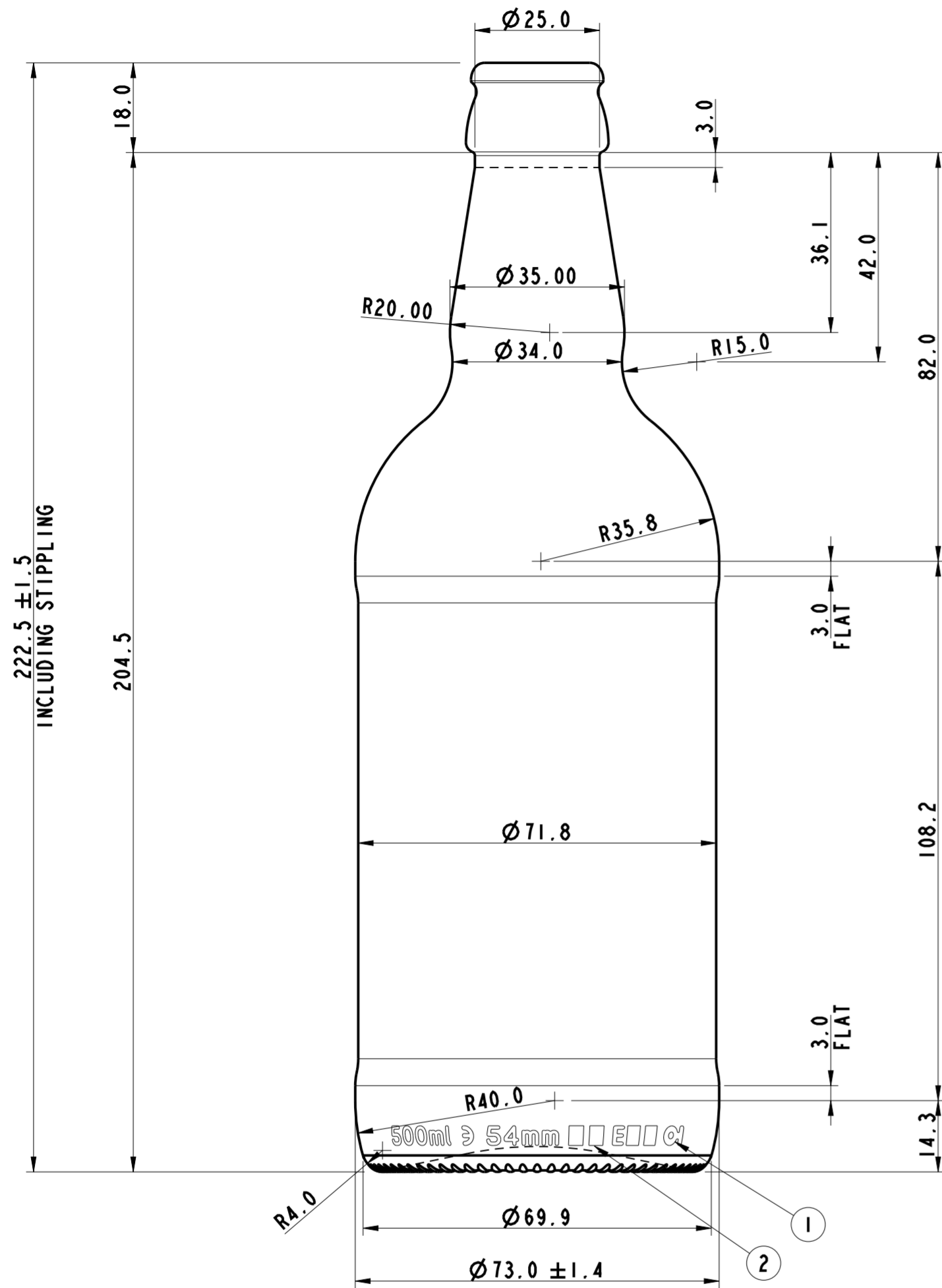

NOTES:
THIS DRAWING IS THE PROPERTY OF O-I AND
MUST NOT BE REPRODUCED OR DISCLOSED
WITHOUT O-I WRITTEN AUTHORIZATION.

ONLY TOLERANCED DIMENSIONS ARE GUARANTEED.

MANUFACTURING MARKINGS SHOWN ARE FOR ILLUSTRATIVE
PURPOSES ONLY. ACTUAL MARKINGS ON CONTAINER
MAY DIFFER, DEPENDANT ON LOCAL LEGISLATION.

SEE BGMTC TEC 4 FOR TOLERANCE INTERPRETATION.
SEE BGMTC TEC 7 FOR CARBONATED BEVERAGES.
HEAT TREATMENT REFERS TO THERMAL PROCESSES OTHER
THAN NORMAL WASHING.
SUBJECT TO INK JET OR LASER CODING BY O-I UNLESS
ADVISED TO THE CONTRARY.

HEAT TREATMENT YES	DO NOT SCALE
VERTICAL LOAD 4000N	VACUITY 4.0%
CATEGORY BEER	TILT ANGLE 21.51°
MAX. VERTICALITY TOLERANCE	MEASURING CONTAINER YES ± 10.0ml
FINISH SAP NUMBER 0733	FINISH REF. CETIE GME 13.01 2003
MINIMUM THROUGH BORE 15.5mm	MAX FILLING TUBE Ø
CONTAINER OVERFLOW CAPACITY (BRIMFUL) 520ml APPROX.	
CONTAINER RATED CAPACITY (FILLPOINT) 500ml ± 6ml	
CONTAINER WEIGHT 280g APPROX.	
CONTAINER WEIGHT EU26_GME 13.01_H180_0733	MAX GAS VOLUME 3.0
PROCESS NO	DESIGN REF. 005145

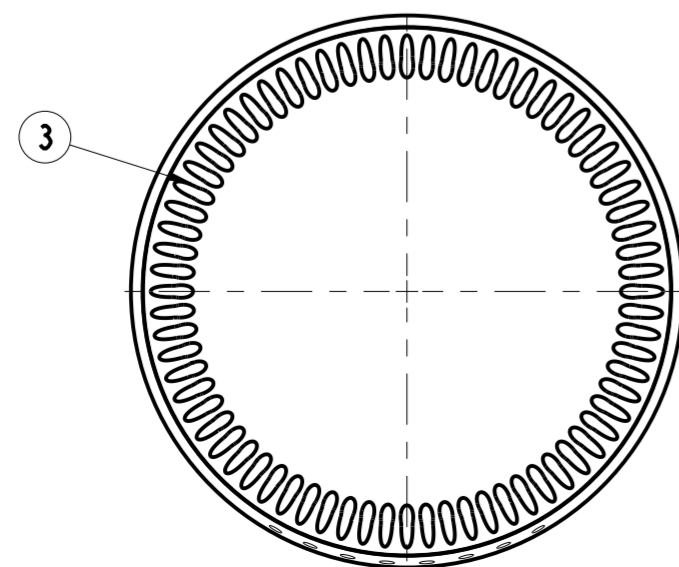

1 : TRADEMARK
2 : CAVITY No.
3 : STIPPLING
THE SHAPE OF STIPPLES IS ONLY AN
INDICATION AND THE CONSTRUCTION IS AT
THE PRODUCTION PLANT DISCRETION.
4 : CAVITY CODE

SCALE 1:1

NNPB ITEM

TENTATIVE

No	DATE	REVISIONS	DESIGN/CHECK
	29-07-14	FULLY DETAILED, DESIGN No WAS BU024, SAP CODE ADDED	LH/DS

STANDARD ITEM
500ml RD NR BEER BOTTLE

DESIGNER	LH	DATE	24/06/14
CHECKED	LH	DATE	24/06/14
DRAWING NUMBER	140664	MOULD/SAP NUMBER	140664